

Current part is item (11) on diagram. Available at www.oshkoshequipment.com

(1) SMR Code	(2) Federal Stock Number	DESCRIPTION	UNIT of meas	QTY inc. in Unit	30-day DS maint allowance	30-day GS maint allowance	1-yr alw per 100 equip cnt- gcy	Depot maint alw per 100 equip	Illustration	(a) Figure No.	(b) Item No.		
		Reference Number & Mfr. Code	Usable On Code		(a) 1-20	(b) 21-50	(c) 51-100	(a) 1-20	(b) 21-50	(c) 51-100			
		COMPOSED OF:											
KFOZZ		2-SHIM: 11610015-1 (19207)										30	21*1
KFOZZ		1-SHIM: 11610015-2 (19207)										30	21*2
KFOZZ		1-SHIM: 11610015-3 (19207)										30	21*3
		0603-STARTING MOTOR											
PAOZZ	2920-088-9372	GASKET SET: STARTER MTG 5702692 (19207)	EA	1	*	*	*	*	*	*	*	31	1
		COMPOSED OF:											
		GASKET: ADAPTER MTG TO FLYWHEEL	EA	1	*	*	*	*	*	*	*	31	1*1
		HOUSING 10889927 (19207)											
PAOZZ	2920-860-9153	GASKET: STARTER MTG TO ADAPTER	EA	1	*	*	*	*	*	*	*	31	1*2
		10889926 (19207)											
PAOZZ	2920-177-9158	ADAPTER, STARTER: MTG 10889928 (19207)	EA	1	*	*	*	*	*	*	*	31	2
PAOFH	2920-763-2346	STARTER, ENGINE, ELECTRICAL: 10951134(19207)	EA	1	*	*	*	*	*	*	*	31	3
		(COMPONENT PARTS) 20-236-35P FOR											
PAOFF	2920-226-6545	STARTER, ENGINE (SOLENOID) (SEE TM	EA	1	*	*	*	*	*	*	*	31	3
		9-2920-242-35 FOR COMPONENT PART) 10911018-1											
		(19207)											
PAOFF	2920-267-9987	STARTER, ENGINE (SOLENOID) (SEE TM 9-2920-243-	EA	1	*	*	*	*	*	*	*	31	3
		34 FOR COMPONENT PARTS) 10935376 (19207)											
PAOFF	2920-999-6216	STARTER, ENGINE (SOLENOID) (SEE TM9-2920-248-	EA	1	*	*	*	*	*	*	*	31	3
		35 FOR COMPONENT PARTS) 10951385-1 (19207)											
PAOZZ	5310-763-8920	NUT, PLAIN, HEXAGON: STARTER MTG TO	EA	3	*	*	*	*	*	*	*	31	4
		FLYWHEEL HOUSING 123305 (24617)											
PAOZZ	5310-045-5001	WASHER, LOCK: STARTER MTG TO FLYWHEEL	EA	3	*	*	*	*	*	*	*	31	5
		HOUSING MS35340-50 (96906)											
		0610-SENDING UNITS											
PAOZZ	6620-814-4770	TRANSMITTER, PRESSURE: ENGINE OIL MS24538-1	EA	1	*	*	*	*	*	*	*	32	1
		(96906)											
PAOZZ	4730-301-7470	COUPLING, PIPE: TRANSMITTER MTG TO ELBOW	EA	1	*	*	*	*	*	*	*	32	2
		444000 (24607)											
PAOZZ	4730-542-5599	ELBOW, PIPE: TRANSMITTER COUPLING MTG TO	EA	1	*	*	*	*	*	*	*	32	3
		CRANKCASE 444055 (24617)											
PAOZZ	6685-814-5271	TRANSMITTER, TEMPERATURE, ELECTRICAL	EA	1	*	*	*	*	*	*	*	32	4
		RESISTANCE: WATER, 120 TO 320 DEG F MS24537-1											
		(96906)											

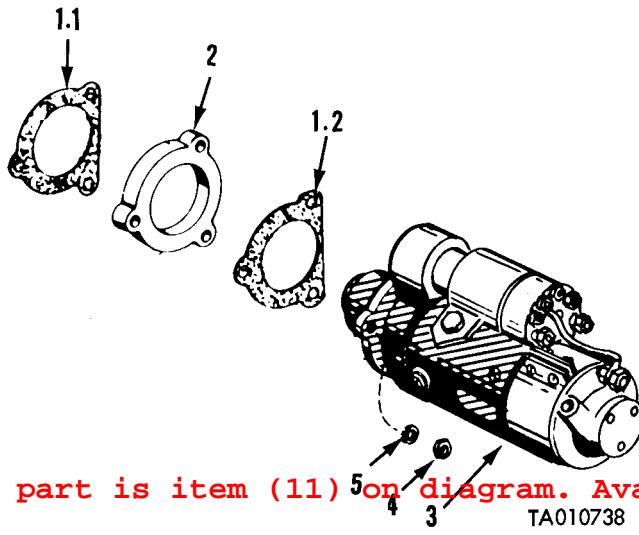

Current part is item (11) on diagram. Available at www.oshkoshequipment.com



Current part is item (11) on diagram. Available at www.oshkoshequip.com

TA010738

Figure 31. Starter and Associated Parts.

